

Operating Instructions

Aspen’s Universal Low Noise Sinusoidal BLDC Drive can be operated in 2 distinct modes. This allows it the ability to seamlessly replace all existing Aspen drives, as well as offer significant compressor noise reduction, lower compressor operational speeds and several different input types for speed control. It also has the ability to operate any compressor in the Aspen Compressor line.

Drive Mode Jumper Configuration –

Mode 1 operation is a direct replacement for the 1501017, 1501018, 1501029, & 1501031 High Performance BLDC drive originally used on all A and Q series compressors. In this mode the drive will behave as a direct replacement for the 1501017/1501018/1501029/1501031 High Performance BLDC drive. To operate in this mode, install a jumper as shown in the picture below. While this mode replicates the performance of the drives listed above, it does not offer the additional low noise, lower operating speeds and additional speed input types that are available when operating in Mode 2. However, there is a provision within this mode to operate taking advantage of the quiet sinusoidal mode only, without the other added functions of operating in Mode 2. See **Note 1** on page 8 for information regarding this.

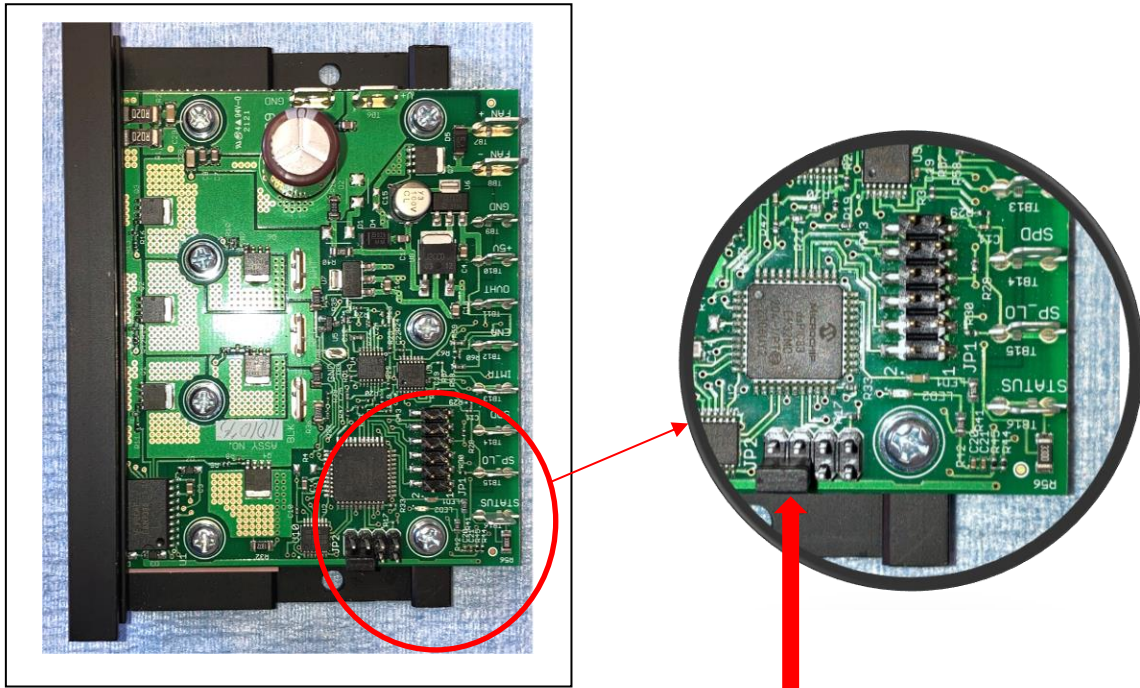

Drive Mode Jumper	JP2 Jumper
Mode 1 1501017, 1501018, 1501029, & 1501031 (Direct Replacement)	Installed As Shown

ASPEN COMPRESSOR

Universal Low Noise Sinusoidal BLDC Drive



Mode 2 operation is a Universal Quiet Sinusoidal drive for all single and twin cylinder compressor models. In this mode, the drive offers ultra-quiet sinusoidal compressor operation as well as enhanced lower operating speeds and additional choices for speed input.

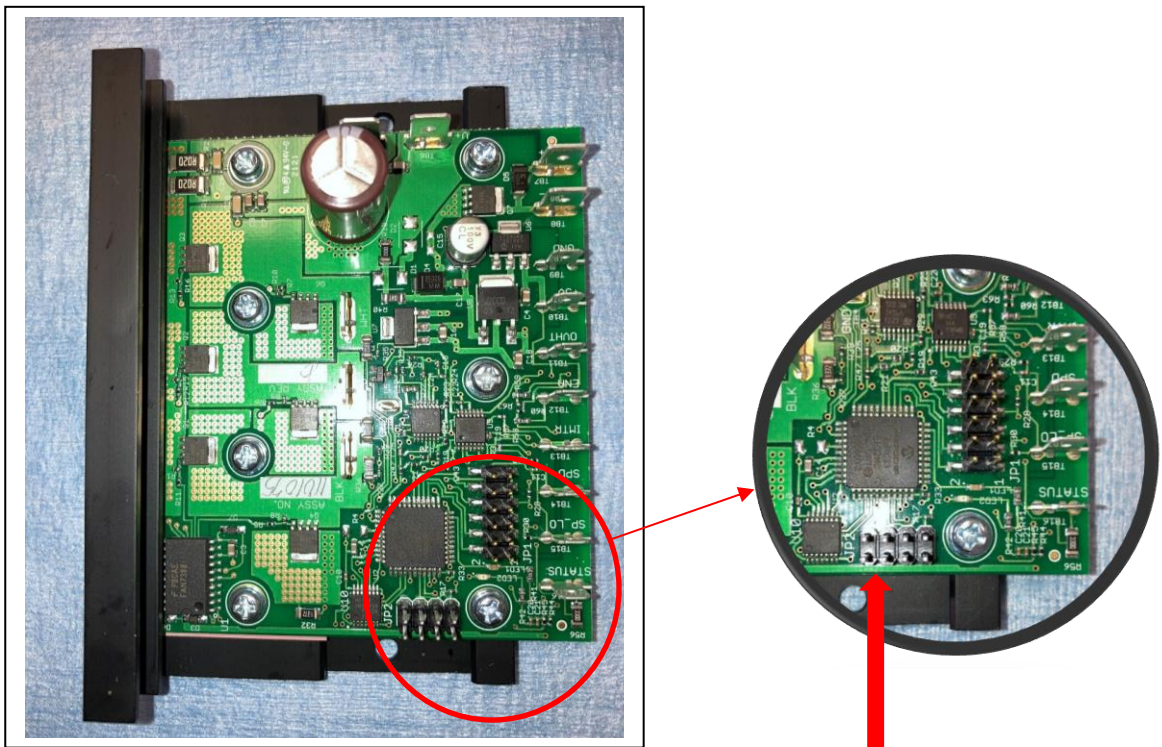

Drive Mode Jumper	JP2 Jumper
Mode 2 Universal Quiet Sinusoidal	Not Installed

Connections

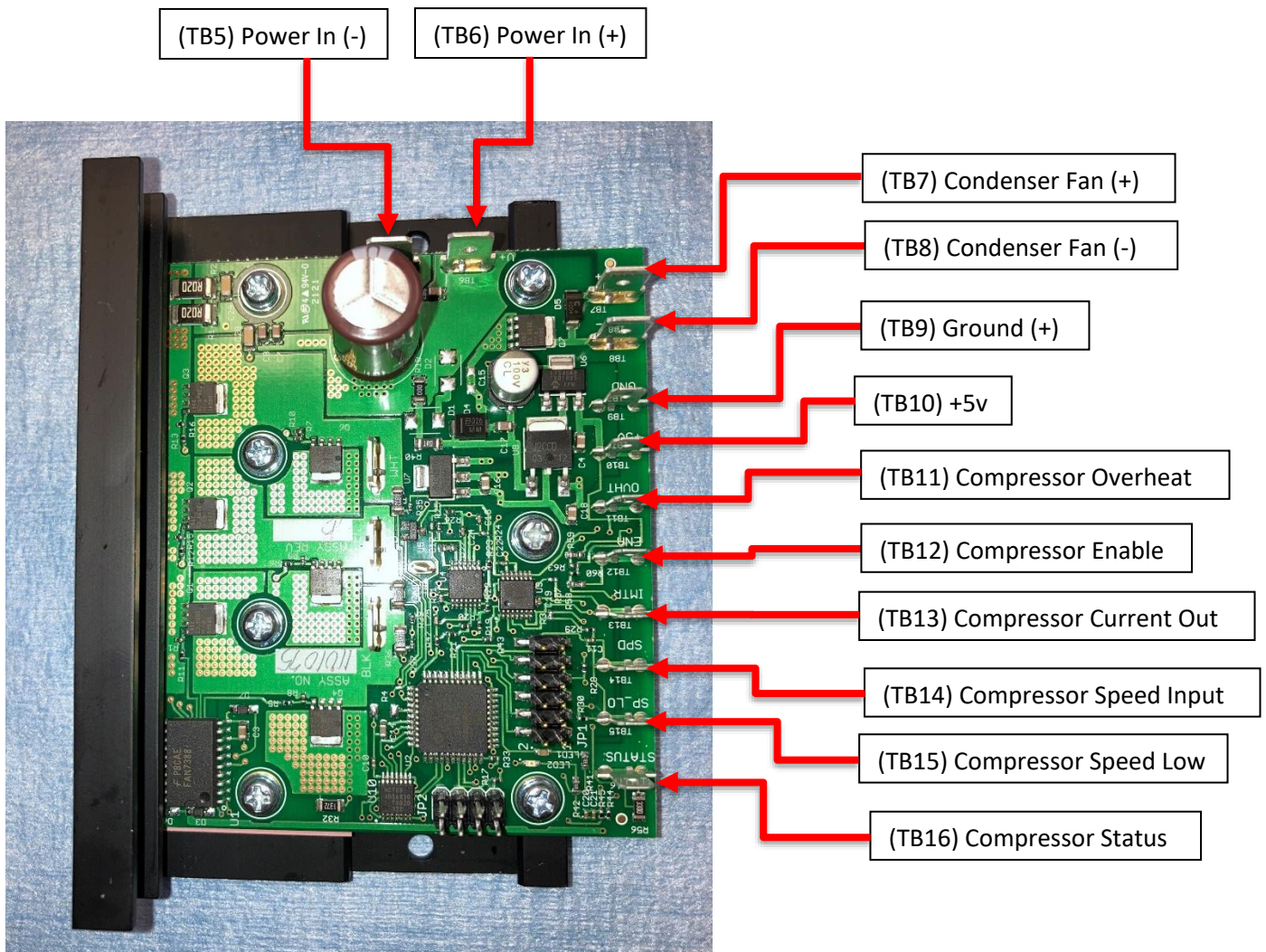

Power Supply Input (TB5 & TB6)

Aspen's Universal Sinusoidal Low Noise Drive is available in 12, 24 and 48 volts.

Drive Board	Operating Voltage Range	Recommend Wire AWG	Recommended Fuse
12 Volt	11-16 Volts	12	15A (Littlefuse 0312015)
24 Volt	20-30 Volts	12	10A or 15A (Littlefuse 0312010 / 0312015)
48 Volt	43-60 Volts	16	8A or 10A (Littlefuse 0312008 / 0312010)

The connections to the drive board power input are two .250" faston tabs.

The use of adequate wire gage and an inline fuse for short circuit protection is required for safe reliable operation. The table above shows the recommended wire gage and fuse size for each of the Aspen drives

1. Condenser Fan Output (TB7 & TB8)

An output has been provided for running condenser fan(s) from the Aspen drive. The voltage of this output will be equivalent to the DC input voltage provided to the board. The power to the condenser fan is enabled 10 seconds after the drive starts the compressor. Therefore, when the compressor is off, the power to the condenser fan(s) is off. When the compressor is signaled to run, the power to the condenser fan(s) will be enabled 10 seconds after the compressor has started running. This 10 second delay is intentional and is meant to reduce the total amount of inrush current when the compressor starts. The connections to the condenser fan outputs are two .250" faston tabs. The condenser fan output should be limited to a maximum of 5 amps on 12/24 volts boards and 3 amps on 48 volt boards.

2. Ground (TB9)

The ground tab is for connecting both the compressor enable and compressor over temp connections to. Both the compressor enable and the compressor overheat connections must be connected to ground in order for the compressor to operate. The connection to the ground is a .187" faston tab.

3. +5V (TB10)

The +5v tab is provided to give the user the ability to provide a low voltage speed signal input without the use of an additional power supply. The 5 volts can be wired directly to the speed input tab, which will cause the compressor to operate at full speed, or can be wired to a 20k potentiometer to allow the user to vary the voltage to the speed input tab and vary the speed of the compressor. The connection to the +5v is a .187" faston tab.

4. Compressor Overheat (TB11)

In order for the compressor to operate, the overheat tab connection must be connected to the thermal safety switch, which is then connected to ground. When used in conjunction with the thermal switch, the drive will shut the compressor off when the thermal switch indicates that the compressor has overheated. Once this has occurred, the board will flash the red LED a sequence of 16 flashes to indicate that the compressor has overheated. To restart the compressor, the thermal switch must reset and the user must either cycle the main power on the drive board or momentarily disconnect the enable wire from ground. The connection to the compressor overheat is a .187" faston tab.

5. Compressor Enable (TB12)

In order for the compressor to operate, the compressor enable tab connection must be connected to ground. This connection can also be wired through a thermostat and then to ground to cycle the compressor on and off via a thermostat. The connection to the compressor enable is a .187" faston tab.

6. Compressor Current Out (TB13)

The drive is equipped with a current out connection to allow the user to monitor the current consumption of the compressor. The current out connection puts out a voltage that correlates to the current being used by the compressor only and not the condenser fans if they are so attached. The correlation is .1 volts per amp, so if the compressor is using 5 amps of power, the voltage measure on the current out tab will be .5 volts. The connection to the compressor current out is a .187" faston tab.

7. Compressor Speed Input (TB14) Mode 1 Operation Only

The connection to the compressor speed input is a .187" faston tab.

In Mode 1 operation, a voltage must be applied to the compressor speed input tab in order for the compressor to operate. The compressor speed input accepts a 0-5 vdc analog voltage signal and will regulate the speed of the compressor automatically with respect to this input voltage per the table below.

Compressor Speed Input / Mode 1 Operation		
1.4 & 1.9 Q and A Series Compressors		
Input	RPM	Option 1 0-5 VDC
Turn Off	2000	~0.65
Turn On	2200	~0.80
Full Speed	6500	4.5

8. Compressor Speed Input (TB14) Mode 2 Operation Only

Enhanced Compressor Speed Range - When operating in Mode 2, the drive has the ability to control speed from 1200-6500 RPM's on T & H series twin cylinder compressors and 1400-6500 RPM's on A & Q series single cylinder compressors. In each instance, the compressor will only reduce speed below 2000 RPM's when the compressor current is below a stable operating threshold. This is done to increase operational reliability and prevent the compressor from stalling at very low operating speeds. There are 4 different options for speed input when operating in Mode 2. The charts and information below show the different input types and speed scaling relationships for both single and twin cylinder compressors. Jumper settings for these options can be found at the end of this section.

Compressor Speed Input / Mode 2 Operation					
1.4cc & 1.9cc Q and A Series Compressors					
Input	RPM	Option 1 0-5VDC	Option 2 0-10VDC	Option 3 4-20mA	Option 4 Frequency hz
Drop Out	1400	~0.65	~1.3	~6.1	~33
Pick Up	1600	~0.80	~1.6	~6.6	~39
Full Speed	6500	4.50	9.00	18.6	180

Compressor Speed Input / Mode 2 Operation					
2.8cc & 3.8cc Twin Series Compressors					
Input	RPM	Option 1 0-5v	Option 2 0-10v	Option 3 4-20mA	Option 4 Frequency
Drop Out	1200	~0.65	~1.3	~6.1	~33
Pick Up	1400	~0.80	~1.6	~6.6	~39
Full Speed	6500	4.5	9.0	18.6	180

Option 1 (0-5v input / Mode 2 Operation Only) - The compressor speed input accepts a 0-5 VDC analog voltage signal and will regulate the speed of the compressor automatically with respect to this

input voltage. There will be a linear increase in speed based on this input voltage. The charts above show the different inputs and speed scaling relationships for both single and twin cylinder compressors when using this option.

Option 2 (0-10 v input / Mode 2 Operation Only) - The compressor speed input accepts a 0-10 VDC analog voltage signal and will regulate the speed of the compressor automatically with respect to this input voltage. There will be a linear increase in speed based on this input voltage. The charts above show the different inputs and speed scaling relationships for both single and twin cylinder compressors when using this option.

Option 3 (4-20mA input / Mode 2 Operation Only) - The compressor speed input accepts a 4-20mA input signal and will regulate the speed of the compressor automatically with respect to this input signal. There will be a linear increase in speed based on this input signal. The charts above show the different inputs and speed scaling relationships for both single and twin cylinder compressors when using this option.

Option 4 (Frequency input / Mode 2 Operation Only) - The compressor speed input accepts a frequency input signal and will regulate the speed of the compressor automatically with respect to this input signal. The frequency signal should be a 5 VDC, 50% duty cycle, square wave. There will be a linear increase in speed based on this input signal. The charts above show the different inputs and speed scaling relationships for both single and twin cylinder compressors when using this option.

9. Compressor Speed Low (TB15)

This tab should be used when a secondary power supply is being used to supply power for speed control and the user wants the secondary supply to be isolated from the power supply being used to power the drive. In this case the factory installed jumper should be removed. This will decouple the board ground reference from the speed signal to allow for minor voltage differences between the power supply grounds. The common mode range is -1.0 to +1.0V. The secondary power supply for speed control can then be wired between the speed input and speed low connections to vary compressor speed. The connection to the compressor speed low is a .187" faston tab. See the jumper configuration table at the end of this section for details.

10. Compressor Status (TB16)

This tab is available to monitor the normal operation of the compressor. When a speed signal is being sent to the drive and the compressor is operating normally, there will be no voltage on this connection. However, if a speed signal is present and the compressor enable is satisfied but the compressor is not running, 5 volts will be present on this tab. This 5v signal can be monitored to alert the end user that there is a problem with the system and that the compressor is not running.

Additional Board Functions

1. **Compressor Start Delay** – The Aspen drive has the ability to delay the compressor start in situations where starting may be difficult due to an unbalanced system. The logic behind the delay is based on a minimum off time for the compressor and can be enabled by installing jumpers per the table at the end of this section. When activated the controller keeps track of how long the compressor has been turned off before trying to restart. If the compressor has been off for the minimum amount of time set by the dip switch when there is a call to restart, it will start immediately. If the minimum amount of time has not passed, the compressor will wait until the minimum time has been reached before attempting to start.
2. **Board Overheat** – The Aspen drive has an onboard thermistor that enables the drive to prevent itself from overheating. When the board detects that it has overheated, the drive will stop the compressor and emit a series of 8 flashes on the red LED.
3. **Automatic Current Limiting** – The Aspen drive has the ability to regulate the amount of current being used by the compressor. The 12v & 24v drives have a user selectable 10 or 15 Amp limit. The 48V has a user selectable 8 or 10 Amp limit. The drive will automatically monitor the current consumption of the compressor. If the compressor begins to draw more than the maximum set current, the drive will automatically decrease the speed of the compressor in an effort to reduce the current being used. Once the speed of the compressor has been reduced below the minimum compressor speed, the drive will stop the compressor and flash the red LED continuously to allow the user to know that the compressor has stalled from excessive current draw or a lock rotor condition. It should be noted that the automatic current limit only reduces the current used by the compressor and does not account for any current that may be drawn by the use of the condenser fan output.
4. **Low Speed Stall Protection** – The Aspen drive allows the compressor a speed range of 1200-6500 RPM's. The drive will only allow the compressor to operate at speeds below 2000 rpm's when the current is below a reliable operating threshold. If the current is not below a reliable operating threshold, the compressor will increase speed automatically between 1200 and 2000 to maintain operational reliability at the lowest possible speed, while preventing the compressor from stalling.
5. **Lock Rotor Protection** - The Aspen drive has the ability to detect if the compressor is not running due to a lock rotor condition. After the drive has made several unsuccessful attempts to start the compressor, the drive will stop attempting to start the compressor and flash the red LED continuously to allow the user to know that the compressor has stalled from excessive current draw or a lock rotor condition.
6. **Error Clearing** – The drive can go in to error mode for several reasons in which case the compressor will stop running. To clear the error and restart the compressor, the enable wire must be disconnected and then reconnected to ground. For a list of error conditions, see the error code table at the end of this document.

Mode 1 Selection Jumper Settings

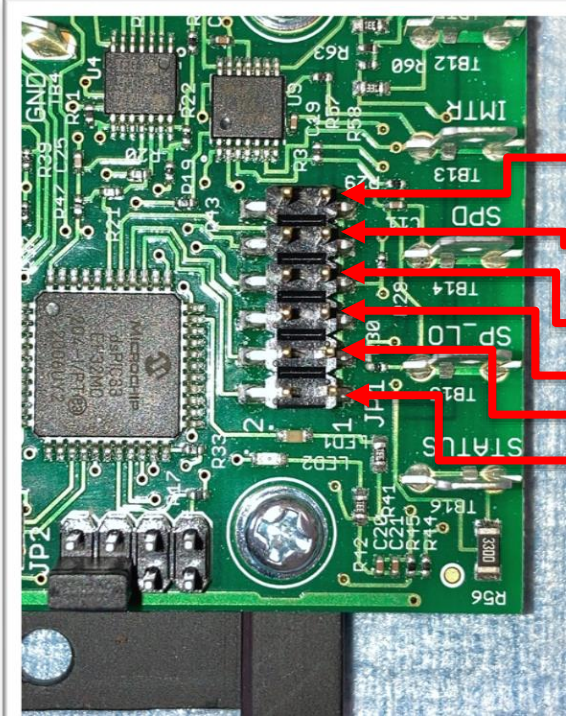

Option Jumpers For Mode 1 Operation
Use This Table When Operating In Mode 1

Jumper Position	Function	Installed	Not Installed
6	Speed Low Isolation	Not Isolated (Factory Default)	Isolated
5	Control Type	Sin Mode See Note 1 Below	Trap Mode See Note 1 Below
4	Current Limit	10 Amps / 12 & 24v 8 Amps / 48v	15 Amps / 12 & 24v 10 Amps / 48v
3	Start Delay	See table below	See table below
2	Start Delay	See table below	See table below
1	Voltage	Consult Factory	Consult Factory

Start Delay	Jumpers To Install
Off	None (Factory Default)
30 sec	Location 2
60 sec	Location 3
120 sec	Location 2 & 3

****Note 1****

Option 5

Trap Mode (jumper not installed)

In this configuration, the drive will operate in trapezoidal motor control mode and will behave exactly like preceding drive models 1501017, 1501018, 1501029, & 1501031 drives.

Option 5

Sin Mode (jumper installed)

In this configuration, the drive will operate in sinusoidal motor control mode. The compressor will operate significantly quieter in this mode. The ramping speed of the compressor will also be reduced to further enhance sound reduction.

Ordering Guide / Drive Part #	Replaces Part #	Comp Type
1501041	1501029	1.4 & 1.9cc Q & A Series 12 Volt / 15 Amp
1501043	1501031	1.4 & 1.9cc Q & A Series 24 Volt / 10 Amp
1501044	1501017	1.4 & 1.9cc Q Series 24 Volt / 15 Amp
1501048	1501018	1.4 & 1.9cc Q Series 48 Volt 8 Amp

Mode 2
 Selection Jumper Settings

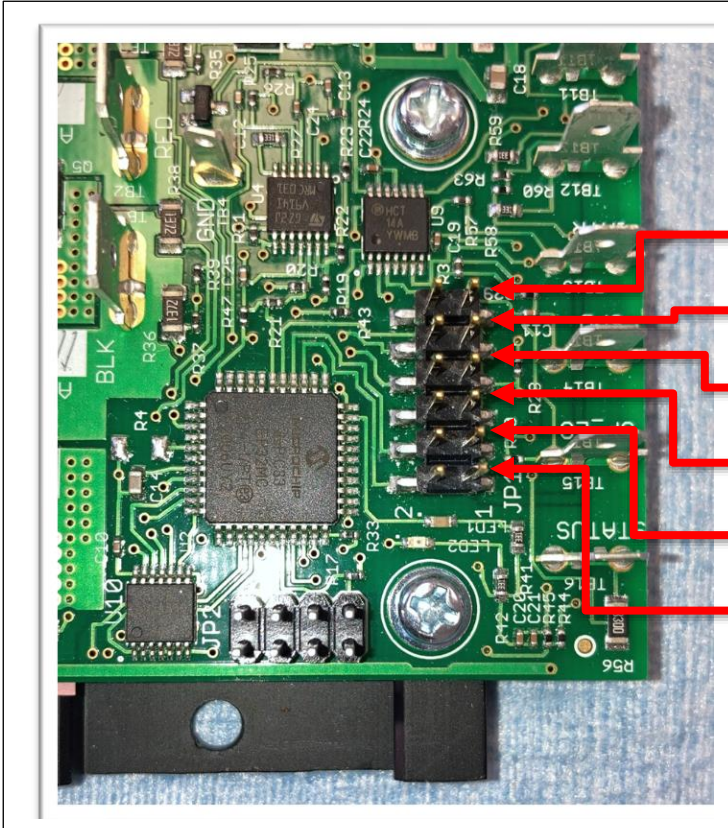

Option Jumpers For Mode 1 Operation			
<i>Use This Table When Operating In Mode 2</i>			
Jumper Position	Function	Installed	Not Installed
6	Speed Low Isolation	Not Isolated <i>(Factory Default)</i>	Isolated
5	Speed Input	See Table below	See Table Below
4	Compressor Type	Consult Factory	Consult Factory
3	Speed Input	See table below	See table below
2	Start Delay	30 Sec	None
1	Compressor Type	Consult Factory	Consult Factory

<i>Speed Input</i>	<i>Jumper Position 3</i>	<i>Jumper Position 5</i>
0 – 5 Volts	Not Installed	Not Installed
0 – 10 Volts	Not Installed	Installed
4 – 20 mAmps	Installed	Not Installed
Frequency (Hz)	Installed	Installed

<i>Ordering Guide / Drive Part #</i>	<i>Comp Type</i>
1501042	1.4 & 1.9cc Q & A Series 12 Volt / 15 Amp
1501045	1.4 & 1.9cc Q & A Series 24 Volt / 10 Amp
1501046	1.4 & 1.9cc Q Series 24 Volt / 15 Amp
1501047	2.8, 3.8, 5.6 & 7.6cc T & H Series 24 Volt / 15 Amp
1501049	1.4 & 1.9cc Q Series 48 Volt 8 Amp
1501050	2.8 & 5.6cc T & H Series 48 Volt 10 Amp
1501052	3.8cc & 7.6cc T & H Series 48 Volt 10 Amp

ASPEN COMPRESSOR

Universal Low Noise Sinusoidal BLDC Drive



** Application Note **

Q-Series compressors operating in mode 1 or 2 may use either the 10 amp or 15 amp setting when operating at 24v and the 8 amp setting when operating at 48v.

A-Series compressors operating in mode 1 or 2 should only use the 10 amp setting when operating at 24v and the 8 amp setting when operating at 48v.

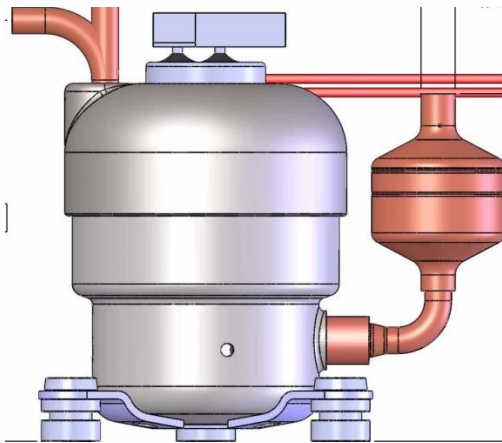

Q Series Compressor

When operating a Q Series compressor in Mode 1 or 2, the current limit jumper can be set to either 10 or 15 amps for 24v compressors and to 8 amps for 48v compressors.

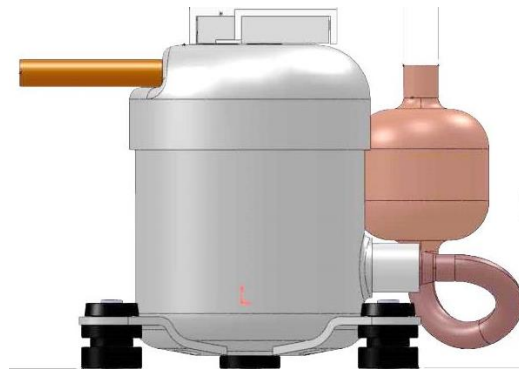

A Series Compressor

When operating an A Series compressor in Mode 1 or 2, the current limit jumper must be set to 10 amps for 24v compressors and 8 amps for 48v compressors.

ASPEN COMPRESSOR

Universal Low Noise Sinusoidal BLDC Drive



Mounting Diagram

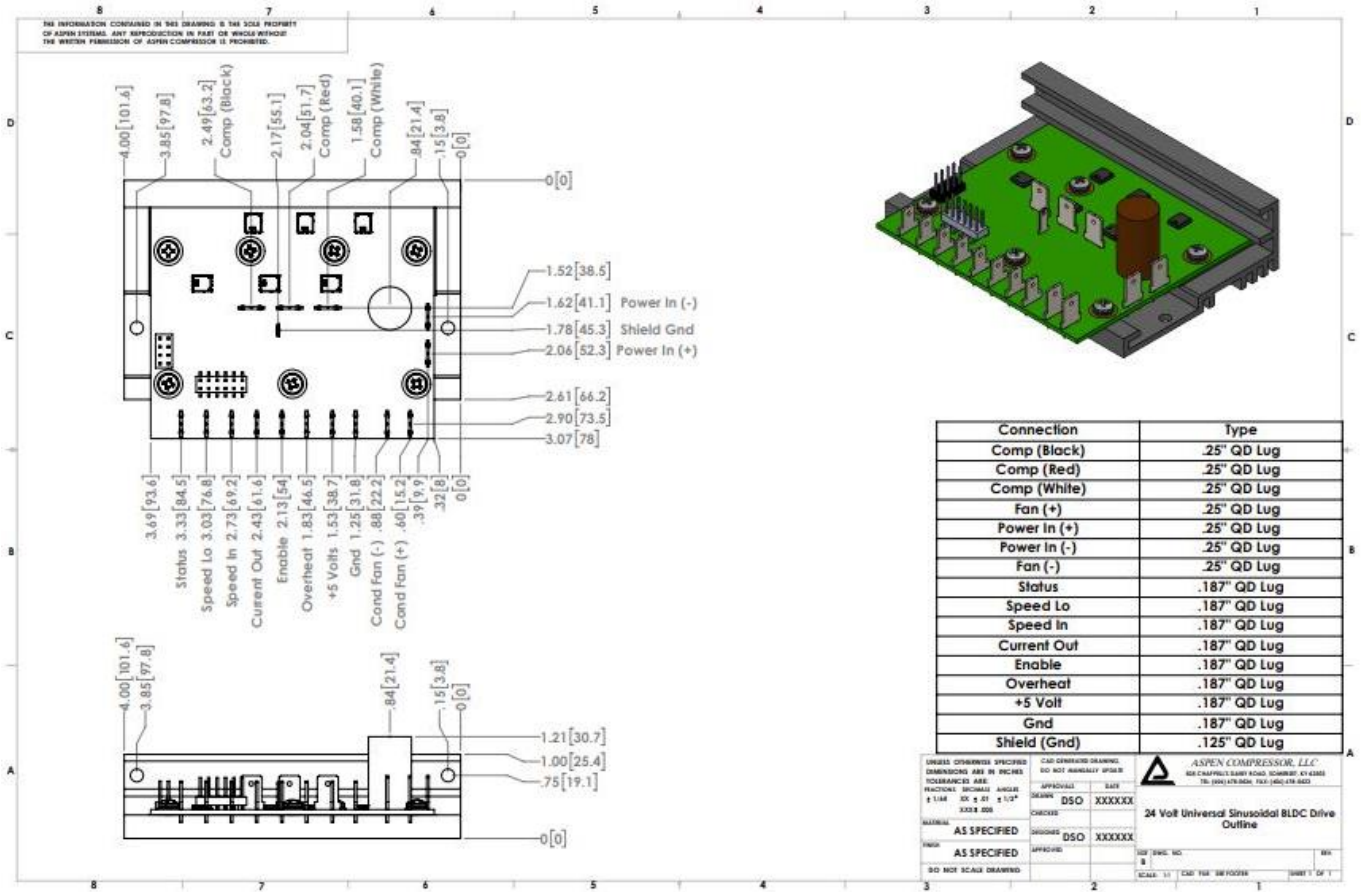

Compressor Wiring – The Aspen Universal Quiet Sinusoidal drive is supplied with a cable to attach the drive to the compressor. All other wiring is to be supplied by the end user. It is important to wire the compressor to the drive with the colors coded in the order per the picture below. If the order of the wires is not correct, the compressor will not operate properly.

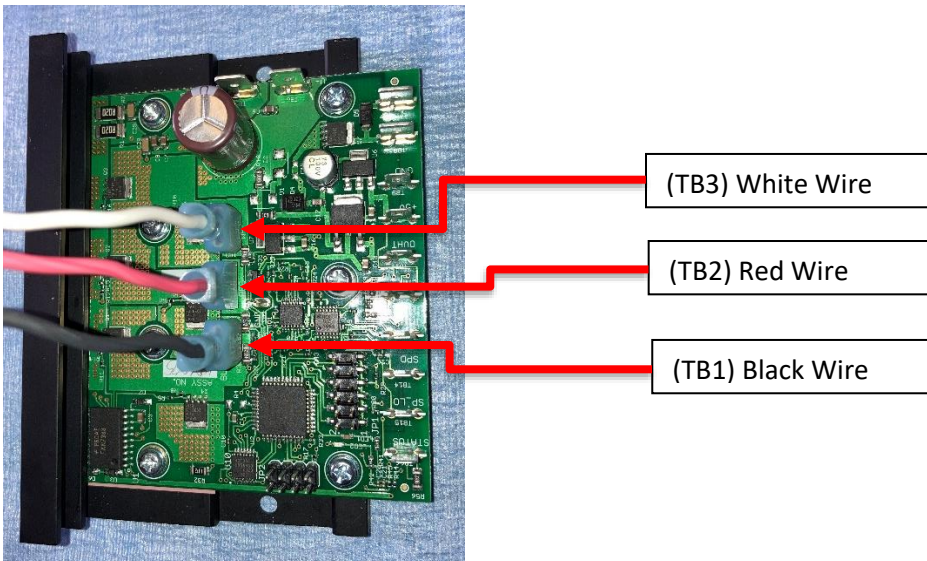

Typical Compressor Wiring

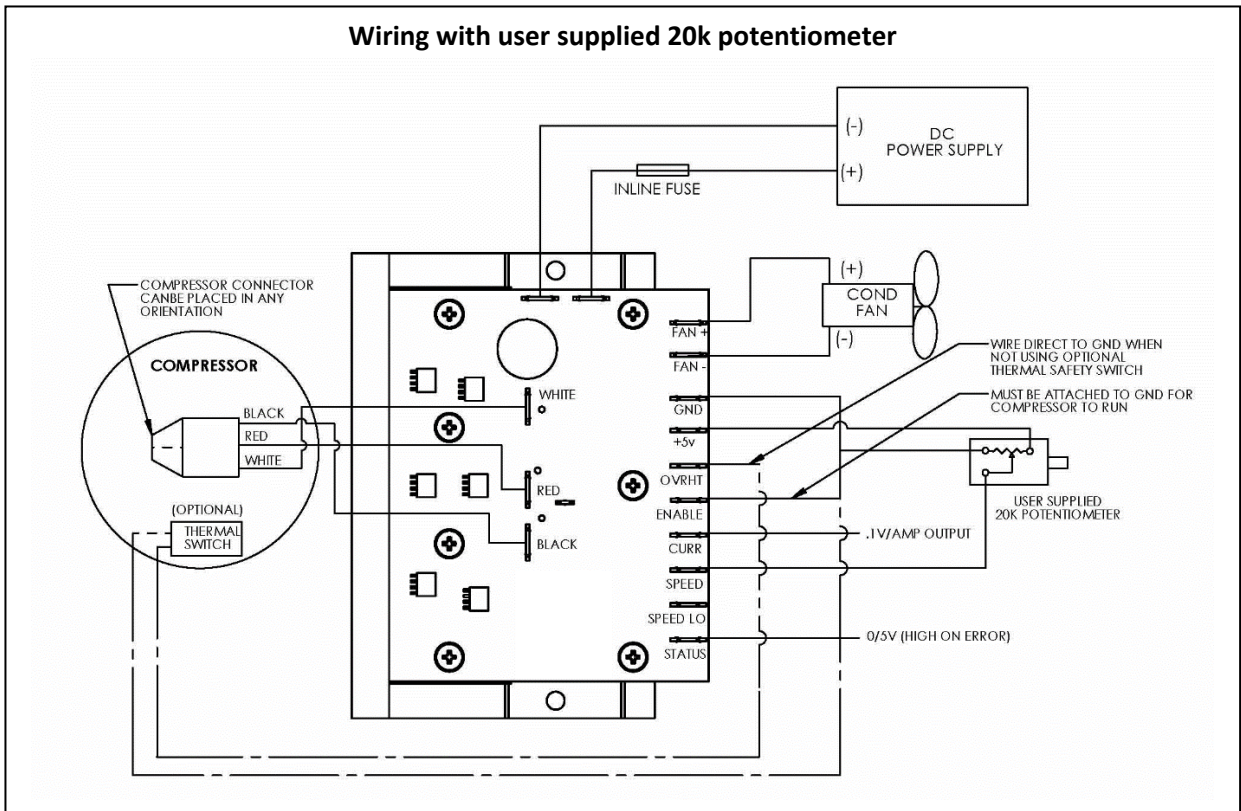
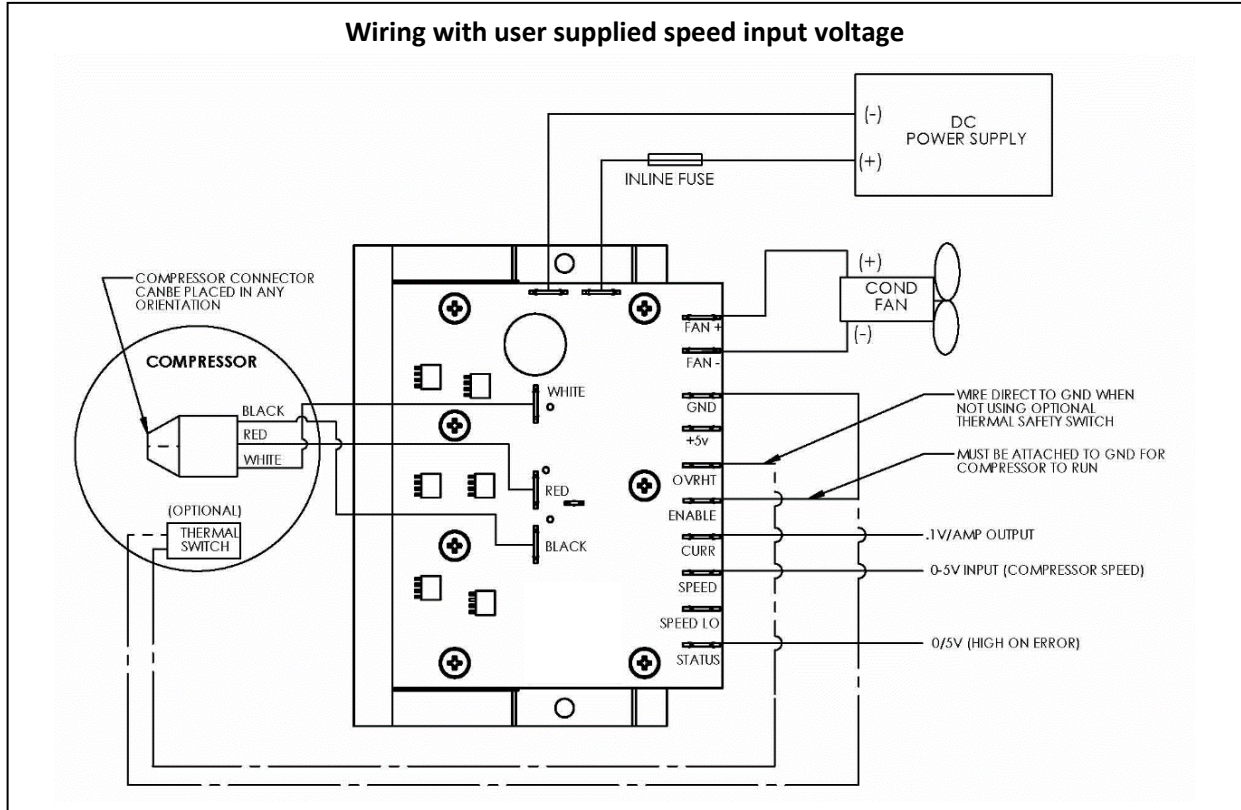

Troubleshooting Guide

Symptom	Possible Cause	Remedy
Compressor will not run when speed input voltage is applied.	<ol style="list-style-type: none">1. Enable connection and or compressor overheat connection is not connected to ground.2. Speed input voltage is less than (.7) volts.3. Loose wire or connection4. Power supply too small, voltage dropping at compressor startup.5. Compressor is in lock rotor condition	<ol style="list-style-type: none">1. Verify enable and overheat connections.2. Verify speed input voltage to be greater than (.7) volts.3. When speed input voltage is applied, verify green light changes from slow flashing (1x/sec) to fast flashing (5x/sec)4. Verify all connections between compressor and drive are in place and in the proper order.5. Measure input voltage to drive board and verify voltage is not dropping below minimum supply voltage when compressor is trying to start.6. Check drive for flashing red light. If red light is flashing, check error code table for appropriate code.
Compressor turns off intermittently.	<ol style="list-style-type: none">1. Compressor overheating2. Drive board overheating3. Loose wire or connection4. Inadequate power supply	<ol style="list-style-type: none">1. Check drive for flashing red light. If red light is flashing, check error code table for appropriate code.2. Verify all wiring connections3. Verify compressor is not drawing more power than power supply can deliver.
Compressor speed ramps up and down automatically	<ol style="list-style-type: none">1. Drive board in current limiting mode2. Drive board close to overheating	<ol style="list-style-type: none">1. Check drive for flashing red light. If red/green light is flashing, check error code table for appropriate code.
Compressor Overheating	<ol style="list-style-type: none">1. Ambient temperature too high2. Inadequate airflow over compressor3. Return gas temperature too high	<ol style="list-style-type: none">1. Increase airflow over compressor2. Verify superheat to be between recommended 8-12 deg. F.
Compressor Current Limiting	<ol style="list-style-type: none">1. Condensing pressure too high.2. Liquid refrigerant being returned to the compressor.	<ol style="list-style-type: none">1. Reduce condensing temperature / pressure.2. Verify superheat to be between recommended 8-12 deg. F.

ASPEN COMPRESSOR

Universal Low Noise Sinusoidal BLDC Drive



Drive LED / Error Code Table	Red LED	Green LED
Normal Operation (Compressor not running)		Slow Flash ~ 1x/sec
Normal Operation (Compressor Running)		Fast Flash ~ 5x/sec
Fault Occurring	Fast Flash ~ 5x/sec	Fast Flash ~ 5x/sec
Compressor stall / lock rotor	1 Flash Repeating	
Supply voltage too high	2 Flashes Repeating	
Supply voltage too low	4 Flashes Repeating	
Board overheated	8 Flashes Repeating	
Compressor overheated	16 Flashes Repeating	